

Government of India
Archaeological Survey of India
Chennai Circle

Fort St. George
Chennai 600 009
Dated :

F.No. 6/3/11/AR&M/KPM/2011-12

NOTICE INVITING TENDER

The Superintending Archaeologist, Archaeological Survey of India, Chennai Circle, Fort St. George, Chennai on behalf of President of India, invites tender in sealed cover for execution of work from only Registered Contractors in ASI, Chennai Circle, Chennai (or) Director General Office at New Delhi. Tenders will be received up to 3.00 p.m. on **16.02.2012** and will be opened in the office of the Superintending Archaeologist, Archaeological Survey of India, Chennai Circle, Chennai on the same day at 3.15hrs.

I. Making and supplying of M.S. grill fence including construction of R.R. Masonry Dwarf wall for the work of Venkatesa Perumal Temple, Thirumukkudal.

Estimated Cost of Rs. 1,80,217/-

EMD:Rs.4,510/-

- | | |
|--|----------|
| 1.Laying foundation concrete using 1:3:6 with 40mm stone jelly | 3.60m3 |
| 2.Construction of R.R. Masonry dwarfwall in CM1:5 | 13.50m3 |
| 3. Pointing the R.R. stone Masonry dwarf wall with CM 1:5 | 63.00m2 |
| 4. Making and supplying of M.S. grill fence | 30.00Rmt |

The Contractor/Supplier will be permitted to attend tender opening. The tender documents are available on website www.asi.nic.in which may be down loaded and should be submitted duly filled along with the earnest money and tender cost separately in the form of Demand Draft of any Nationalized Bank obtained in favour of the "Superintending Archaeologist, Archaeological Survey of India, Chennai Circle, Chennai-9". A separate DD towards VAT should be obtained in favour of the Commercial Tax Officer, Esplanade, Chennai. **All tender forms downloaded from ASI website shall be accepted only if the tender form cost is remitted while submitting the tenders**

The tender forms of contractors who do not deposit earnest money, tender cost and VAT as prescribed will be summarily rejected. The sealed cover should be superscribed with the name of work & opening date.

Tender documents can also be obtained on all working days on payment of **Rs.500/-** plus VAT (non-refundable) upto **14.02.2012** from the following:

The Conservation Assistant
Archaeological Survey of India
Kanchipuram sub-circle
Kanchipuram.

AND

The Superintending Archaeologist
Archaeological Survey of India
Chennai Circle, Fort St. George
Chennai 600 009.

The undersigned reserves the right to reject any or all the tender without assigning any reason.

Superintending Archaeologist

Price of Tender – **Rs.500/- + VAT 14. 5%**

P.W.D. 9 (Tender) – A.S.I.

TENDER FOR EXECUTION OF WORK

I/We hereby tender for execution of work for the President of India described in the under mentioned memorandum according to the specification within the times specified and that the rates specified therein subject to the conditions of the contract :- **AR&M to Venkatesa**

Perumal Temple, Thirumukkudal

MEMORANDUM - (i) Earnest Money : **Rs. 4,510/-**

(ii) Security Deposit : **Rs. 10%** made up as under :- **Estimated Cost of Rs1,80,217/-**

a) Payable immediately on the acceptance of tender (including earnest money if deposited in cash with tender _____ Rs. _____

b) Percentage to be deducted from bill* _____ Rs. _____

Description of work	Total work to be executed	Places at which to be executed	Quantities to be executed at each place	Dates by which Works to be executed	Rates* at which items are to be executed inclusive of every demand	Unit	Total cost of each work inclusive of every demand	Remarks
1	2	3	4	5	6	7	8	9
1.Laying foundation concrete using 1:3:6 with 40mm stone jelly consolidating and curing etc. complete including cost of materials and labour charges (as per the directions of dept. officials)	3.60m3	At site		30 days		1m3		
2. Construction of R.R. Masonry dwarf wall in Cement Mortar 1:5 curing etc. complete including cost of materials and labour charges etc.(as per the directions of dept. officials)	13.50m3	-do-		-do-		1m3		
3. Pointing the R.R. stone masonry dwarf wall with cement mortar 1:5 curing etc. complete including cost of all materials and labour charges etc.(as per the directions of dept. officials)	63m2	-do-		-do-		10m2		
								Contd..2

*This percentage, where no security deposit is taken, will vary from 5% to 10% according to the requirements of the case. Where security deposit is taken see note to clause 1 of conditions of contract.

Price of Tender – **Rs.500/- + VAT 14. 5%**

P.W.D. 9 (Tender) – A.S.I.

TENDER FOR EXECUTION OF WORK

I/We hereby tender for execution of work for the President of India described in the undermentioned memorandum according to the specification within the times specified and that the rates specified therein subject to the conditions of the contract :- **AR&M to Venkatesa Perumal Temple, Thirumukkudal**

MEMORANDUM - (i) Earnest Money : **Rs. 4,510/-**

(ii) Security Deposit : **Rs. 10%** made up as under :- **Estimated Cost of Rs. 1,80,217/-**

a) Payable immediately on the acceptance of tender (including earnest money if deposited in cash with tender _____ Rs. _____

b) Percentage to be deducted from bill* _____ Rs. _____

Description of work	Total work to be executed	Places at which work to be executed	Quantities to be executed at each place	Dates by which Works to be executed	Rates* at which items are to be executed inclusive of every demand	Unit	Total cost of each work inclusive of every demand	Remarks
1	2	3	4	5	6	7	8	9
4.Making and supplying of M.S. grill fencing using 50 x 50 x 6mm 'L' angle as vertical post with 50 x 6mm M.S. flat in horizontal @ equal intervals and 16mm M.S. round @10cm c to c and painting with two coats of synthetic enamel paint over a coat of primer etc. and fixing M.S. grill fencing with 'L' angle Iron frame M.S. grill etc. in P.C.C. 1:2:4 with providing coping to the R.R. Masonry dwarf wall using P.C.C. 1:2:4 and finishing the top required slope curing etc. complete including cost of materials and labour charges etc.(as per the directions of dept. officials)(as per sketch enclosed)	30Rmt	At site	-	30 days	Contd. from pre-page	1Rmt		

Superintending Archaeologist

Signature of the Contractor

*This percentage, where no security deposit is taken, will vary from 5% to 10% according to the requirements of the case. Where security deposit is taken see note to clause 1 of conditions of contract.

Should this tender be accepted, I/We hereby agree to abide by and fulfil all the terms and provisions of the said conditions annexed hereto so far as applicable, and/or in default thereof to forfeit and pay to the President of India or his successor in office the sum of money mentioned in the said conditions. A sum of Rs. _____* is herewith forwarded in Cash/Treasury Challan as earnest money. If I/We fail to commence the work to specified in the above memorandum or if I/We fail to deposit the amount of security deposit specified against (ii) (a) in the above memorandum in accordance with clause 1 of the said conditions of contractor I/We agree that the said President or his successors in office shall, without prejudice to any other right or remedy, shall be retained by his towards such security deposit. I/We further agree that the said President or his successors in office shall also be at liberty to cancel the acceptance of the tender if I/We fail to deposit security amount to aforesaid.

* Give particulars & numbers

Signature

Address

Signature of witness to Signature of tender

Address

Dated

the 2012

The above tender is hereby accepted by me behalf of the President of India.

Dated :

the 2012

**Signature of the officer by whom
the tender is accepted**

NAME OF WORK : *AR&M TO* SRI VENKATESA PURMAL TEMPLE AT THIRUMUKKUDAL -2011-12

Cross section of proposed MS grill fencing on the protected area (part) north of Tiruvannamalai road, 250Rmt.

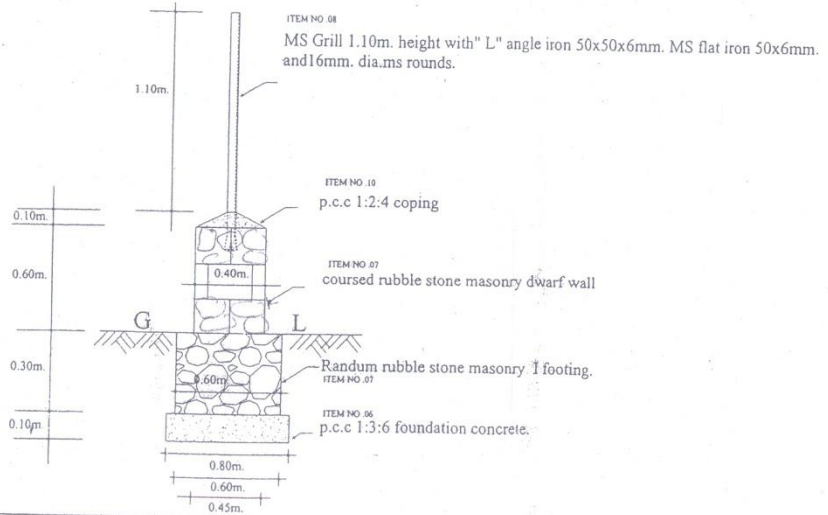

ad
Conservation Assistant,
Archaeological Survey of India,
Kanchipuram Sub-Circle, Kanchipuram.

Paal
Assistant Superintending
Archaeological Engineer
ARCHAEOLOGICAL SURVEY OF INDIA
CHENNAI CIRCLE
CHENNAI - 600 009.

3/12
Superintending Archaeologist,
Archaeological Survey of India,
Chennai Circle Fort St. George,
Chennai - 600 009.

NAME OF WORK : ARADAN TO S. VENKATESA PERUMAL TEMPLE AT THIRUMUKKUDAL - 2011-12

M.S GRILL FENCING PROPOSED UNDER ITEM NO. 8

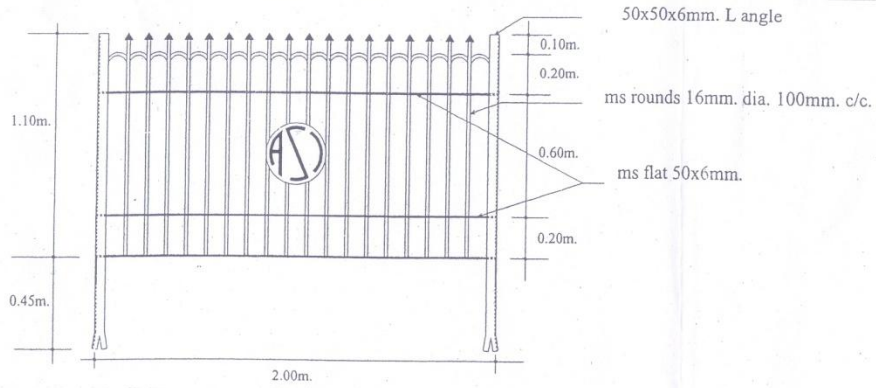

[Signature]
Conservation Assistant,
Archaeological Survey of India,
Kanchipuram Sub Circle, Kanchipuram.

[Signature]
o/c Assistant Superintending
Archaeological Engineer
ARCHAEOLOGICAL SURVEY OF INDIA
CHENNAI CIRCLE
CHENNAI - 600 009.

[Signature]
o/c Superintending Archaeologist,
Archaeological Survey of India,
Chennai Circle Fort St. George,
Chennai - 600 009.