

**GOVERNMENT OF INDIA
ARCHAEOLOGICAL SURVEY OF INDIA
CHURCH COMPLEX, OLD GOA**

TENDER NOTICE

The Superintending Archaeologist, Archaeological Survey of India, Goa Circle, Church Complex, Old Goa, on behalf of the President of India, invites percentage/item rate tender for execution of work in sealed cover from approved C.P.W.D/P.W.D/M.E.S/Public under taking contractors upto 15.00 hrs on 29.11.2011 and will be opened on the same day at 15.30 hrs for execution of work.

Name of the work : Construction of septic tank and soak pit for toilet block at Upper Fort Aguada.
Estimated cost of the material/work : Rs. 1,20,112.00
Earnest Money : Rs. 3,003.00

Tenders of the contractors who do not deposit earnest money of Rs. 3,003/- along with the application in favour of the Superintending Archaeologist in the prescribed form will be summarily rejected.

Conditions and form of tenders can be had from the office of the Superintending Archaeologist, Archaeological Survey of India, Goa Circle, Church Complex, Old-Goa, between the hours of 10.00 hrs to 17.00 hrs on all working days on payment of Rs. 550/- (not refundable) till 28.11.2011.

The tender document is also available on website www.asigoacircle.com and www.asi.nic.in which may be downloaded and submitted along with the cost of tender form.

The contractor/tenderer/supplier is permitted to attend the tender opening.

The material/ work should be supplied/executed as specified in the tender schedule.

The lowest approved rates shall be valid up to 31-03-2012.

If the date of issue or receipt of the tender happens to be holiday, the tenders will be issued or opened on the next working day.

The right to accept or reject any or all the tenders including lowest one without assigning any reason thereof is reserved. Canvassing in any form would be considered as demerit and the tender is liable to be cancelled.

Superintending Archaeologist
Archaeological Survey of India
Church complex, old Goa

No. 5/20/ 2011-12-Con- Dated:

1. The Director General, Archaeological Survey of India, Janpath, New Delhi.
2. The Assistant superintending Archaeological Engineer, ASI, Goa Circle, Goa.
3. The Pay and Accounts Officer, Archaeological Survey of India, Hyderabad.
4. CAI /CA II, Church complex, Old Goa for information and to send copy of tenders to Government offices, panchayat for wide publicity.
5. Office Notice board.

**GOVERNMENT OF INDIA
ARCHAEOLOGICAL SURVEY OF INDIA
CHURCH COMPLEX, OLD GOA**

Name of work: Construction of septic tank and soak pit for toilet block at Upper Fort Aguada,

P.W.D- 9 (Tender)

Date of tender opening: 29.11.211

Price of Tender: Rs. 600/- (550 + 50 drawing)

TENDER FOR THE EXECUTION OF WORK

Tender No. 16/11-12 ()

I/We hereby tender for the supply for the President of India the materials described in the under mentioned memorandum according to the Specification within the times specified therein subject to the conditions of the contract:-

MEMORANDUM- (i) Earnest Money **2.5% Rs. 3003.00** Security Deposit..... **Rs.**

(a) Payable immediately on the acceptance of tender (including earnest money if deposited in cash with tender **Rs.....**

(b) Percentage to be deducted from bill **2.24% Income Tax**

Description or specification of materials to be supplied	Total quantity of work to be executed	Place at which work to be executed	Quantity of work to be executed	Dates by which work to be completed	Rates at which work to be executed inclusive of every demand	Unit	Total cost of work inclusive of every demand *	Remarks
1	2	3	4	5	6	7	8	9
Construction of septic tank and soak pit at Upper fort Aguada as per the Annexure - I and drawing.	As per Annex.I	Upper Fort Aguada	Whole	45 days				

*The contractor / firm should quote the rate in figures as well as in words and after site inspection.

SIGNATURE OF THE CONTRACTOR WITH ADDRESS

ANNEXURE I**Tender No.16/11-12()****ARCHAEOLOGICAL SURVEY OF INDIA
GOA CIRCLE, OLD GOA**

Sl. no	Description of Work	Quantity	Rate	Amount
A	Earthwork excavation in hard laterite soil including dressing of sides, ramming of bottom and getting out the excavated soil and disposal of the same away from the site, etc. complete.	28.00 Cum		
B	Providing and laying cement concrete of 0.10 m thick in 1:3:6 (1 cement :3 sand:6 coarse aggregate) for PCC bed of septic tank including proper compacting, slope, curing, carrying materials, etc. complete.	1.20 Cum		
C	Providing and constructing the walls of septic tank in laterite stone masonry in cement mortar 1:4 including proper joints, carrying materials, curing, etc. complete.	8.40 cum		
D	Providing and laying cement concrete for RCC slab of 0.15m thick in 1:2:4 on the top of septic tank including carrying materials, curing, etc., complete.	1.20 Cum		
E	Providing reinforcement in the RCC slab including bending, cranking and binding steel bars in position and centering and shuttering both erection and dismantling etc. complete.	1.20 Cum		
F	Providing 12mm thick plastering for the interior portion of the septic tank in CM 1:2 including carrying materials, curing, etc. complete.	36.40 Cum		
G	Providing and filling rubble packing in the soak pit not less than 15 cm etc. complete	12.00 Cum		
		TOTAL		

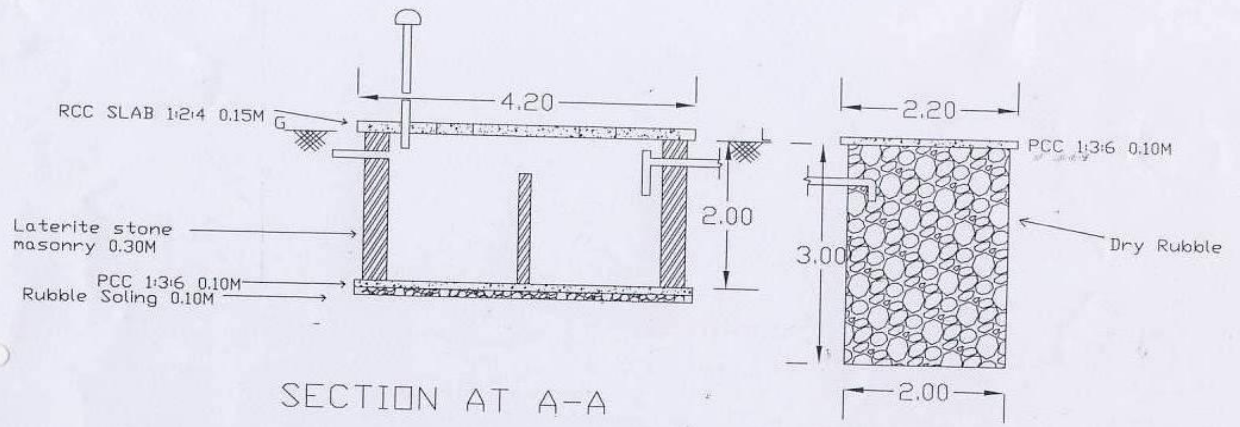

SECTION AT A-A

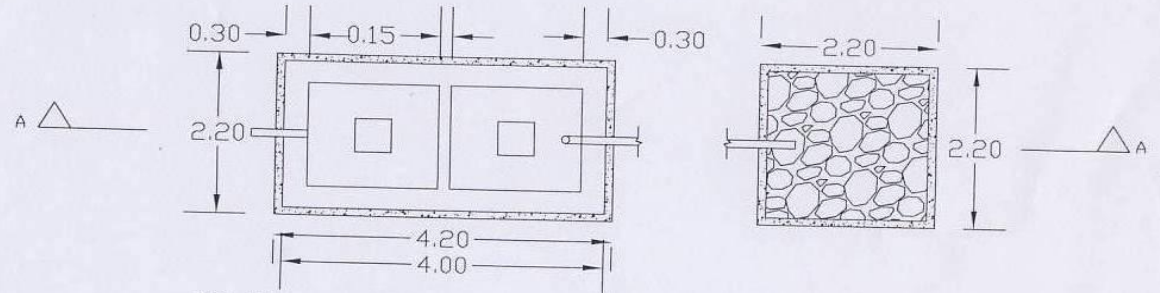

PLAN - SEPTIC TANK AND SOAK PIT

**GOVERNMENT OF INDIA
ARCHAEOLOGICAL SURVEY OF INDIA
CHURCH COMPLEX, OLD GOA**

TENDER No.16/11-12()

NO: 5/20/11-12- Con -

Name of work: Construction of septic tank and soak pit for toilet block at Upper Fort Aguada

- 1 Sale Price of Tender : Rs.600/- (Non-Refundable)
 - 2 Name of the Contractor / Firm :
 - 3 Date of Application for Tender :
form by Contractor / Firm
 - 4 Date of Receipt of Application in :
Circle/Branch Office
 - 5 Cash Receipt No. & Date :
 - 6 Date of Issue of Tender Paper :
 - 7 Date of Receipt of Tender Paper :
 - 8 Date of Opening the Tender : 29.11.2011
 - 9 E.M.D. Enclosed or not : YES / NO.
- Vide D.D. No:**
Date:
- 10 Name & Designation of the
Officer Opening the Tender :
 - 11 Details of Cuttings, Over
writings and erasing found on :
the Tender
 - 12 Name of Officers who were : a)
Present while Opening the
Tender : b)
: c)
: d)
 - 13 Name and signature of the
Contractor / Firm who were :
Present while Opening the
Tender

Should the Tender be accepted, I/We hereby agree to abide by and fulfill all the terms and Provisions of the said Conditions annexed here to so far as applicable and or in default thereof to forfeit and pay to the President of India or his successors office the sums of money mentioned in the said conditions.

A Sum of Rs. _____ is herewith forwarded in form of Demand Draft/Treasury Challan as Earnest Money Deposit. If I/We fail to deposit the amount of Security Deposit specified against to deposit ii (a) in the above memorandum in accordance with clause 1 of the said conditions of Contract.

I/We agree that the President or his successors in office shall, without prejudice to any other right or remedy, be at liberty to forfeit the said Earnest Money Deposit shall be retained by him towards such Security Deposit.

I/We further agree that said President or his successors in office shall also be at liberty to cancel the acceptance of the Tender if I/We fail to deposit the Security amount as aforesaid.

Place:

SIGNATURE:

Date:

ADDRESS :

Signature of Witness to Signature of Tender

Date the:

Signature & Address

The above Tender is hereby accepted by me on behalf of the President of India.

Dated the:

Date:

Signature of the Officer by
Whom the Tender is accepted

NO: 5/20/2011-12-Cons.

**GOVERNMENT OF INDIA
ARCHAEOLOGICAL SURVEY OF INDIA
CHURCH COMPLEX, OLD GOA**

STATE: GOA

BRANCH: ASI, GOA CIRCLE

NAME OF THE WORK: Construction of septic tank and soak pit for toilet block at Upper Fort Aguada,

TENDER FORM No: 16/11-12 []

ISSUED TO SRI. :

TENDER & CONTRACT FOR SUPPLY OF MATERIALS

GENERAL RULES AND DIRECTIONS FOR THE GUIDANCE OF CONTRACTORS

1. All Supplies proposed to be obtained by contract will be notified in a form of invitation to Tender pasted in public places and signed by the Superintending Archaeologist.
2. This form will state the supplies to be made, as well as the date for submitting and Opening Tenders and the time allowed for carrying out the work /Supply the Material / s, also the amount of Security Deposit to be deposited by the Successful Tenderer and the percentages to be deducted from Bills, Copies of the Specifications, and any other documents required in connection with the work, signed for the purpose of identification by the Superintending Archaeologist shall also be open for inspection by contractor at the office of the Superintending Archaeologist during Office hours.
3. In the event of the Tender being submitted by a firm, it must be signed separately by each member therefore, or in the event of absence of any Partner, it must be signed on his behalf by a person holding a Power-of-Attorney, authorizing him to do so, much power of Attorney to be produced with the Tender and it must disclose that the firm is duly registered under the India Partnership Act.
4. Receipt for payments made to a firm, must also be signed by the several partners, except where the contractors are described in their Tender as a firm, in which case the receipts must be signed in the name of the firm by one of the Partners, or by some other person having authority to give effectual receipt for the firm.

5. Any Person who Submits a Tender shall fill up the usual printed form, stating at what rate he is willing to undertake each item of the work, tenders which propose any alteration in the work specified in the said form of Invitation of Tender, or in the time allowed for carrying out the work, or which contain any condition of any sort, will be liable for rejection. No Single Tender shall include more than one work, but contractors who wish to tender for two or more works shall submit a Separate Tender for each. Tender shall have the name and number of the work which they refer written outside the envelope.
6. The Superintending Archaeologist or his duly Authorized Assistant will open Tenders in the Presence of any intending contractors who may be present at the time, and will enter the amounts of several Tenders in a Comparative statement in a suitable form. In the event of a Tender being accepted, a receipt for the earnest money forwarded herewith shall there upon be given to the contractor who shall there upon for the purpose of Identification sign copies of the Specifications and other documents as mentioned in Rule. 1. In the event of a Tender being rejected, the earnest money forwarded with such un-accepted Tender shall there upon be returned to the contractor making the same.
7. The Officer inviting Tenders shall have the right of rejecting all or any of the Tenders, and will not be bound to accept the Lowest Tender.
8. The receipt of an Accountant or Clerk for any money paid by the contractor will not be considered as any acknowledgement of Payment to the Superintending Archaeologist and the Contractor shall be responsible for seeing that he procures a Receipt signed by the Superintending Archaeologist, or a duly Authorized Cashier.

Superintending Archaeologist

Signature of Contractor